



CILINDRICAL ROLLER BEARINGS

Applications

Common Applications

TIMKEN
Where You Turn

CRB Applications

- Common in many industrial applications where radial loads are prevalent



Flat and Long Product Rolling Mills

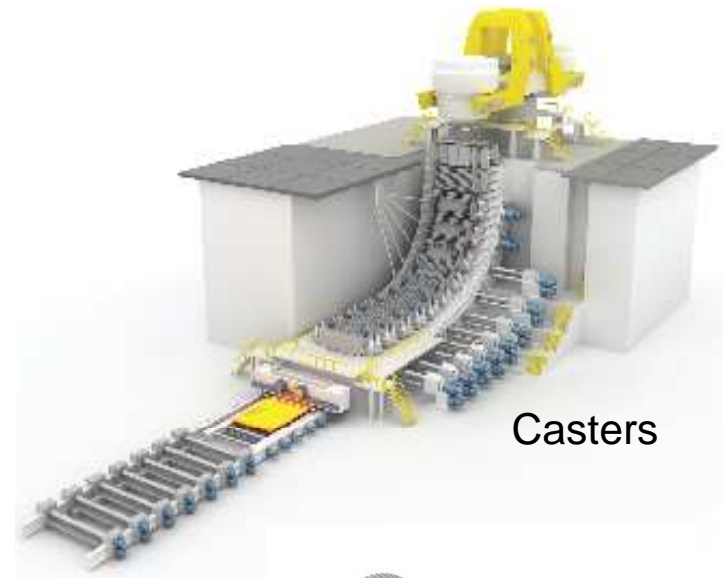

Casters

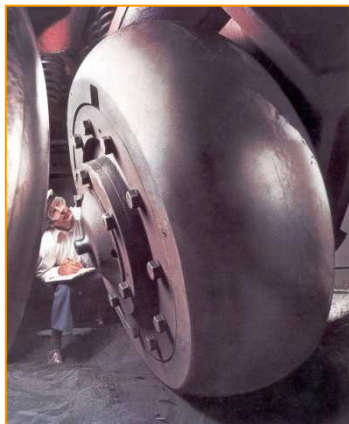

Coal Pulverizer Wheels

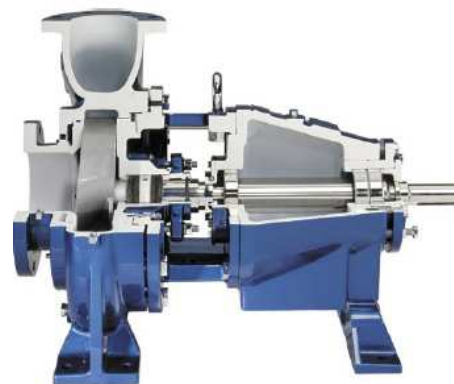

Slurry Pumps

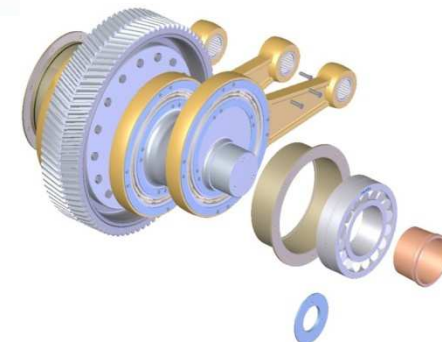

Mud Pumps

Metals - Continuous Caster

- Slab leaves mold and travels down [sometimes through a bender] to the Bow and Straightener sections
- At the bottom of the caster, continuous bar cut into separate bars by a gas torch

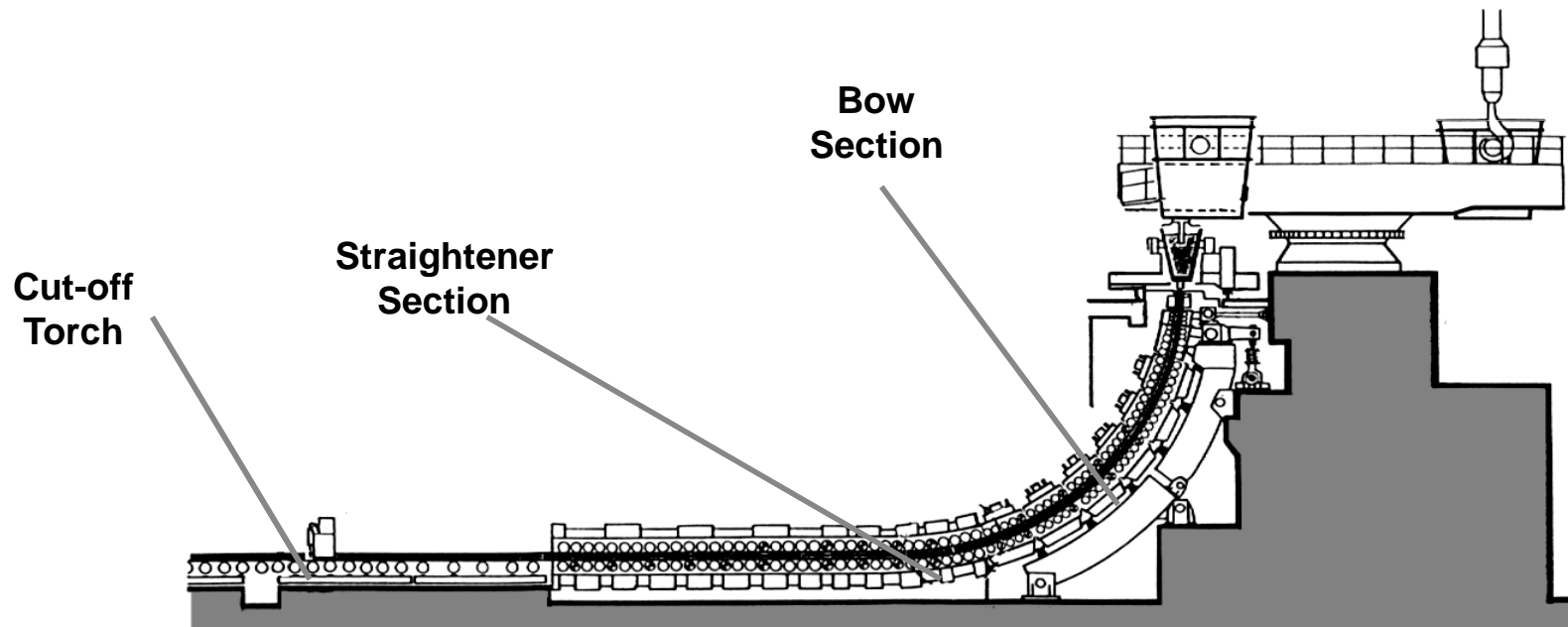

Metals - Continuous Caster

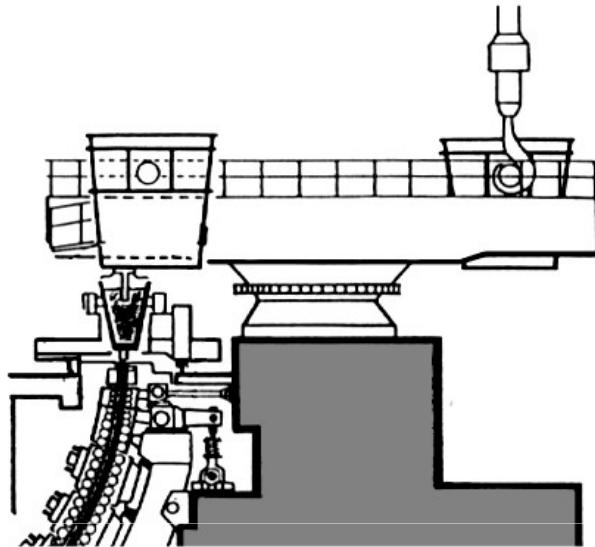

Ladle Turret

- Cylindrical, spherical, taper and ball thrust bearings up to 1200 mm (47.25 in) bore
- Radial cylindrical and spherical bearings

Mold Oscillator

- Spherical, taper and cylindrical bearings with heavy duty cages and tight tolerances

Strand Segments

- Drive rolls:
Spherical and cylindrical roller, split spherical, or split cylindrical roller bearings
Water cooled split housings
- Idler rolls:
Needle, spherical and cylindrical roller bearings

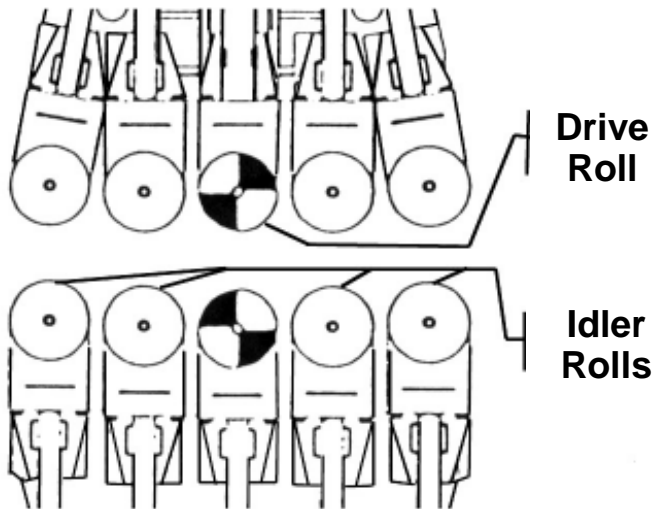

Continuous Caster - Segment Rolls

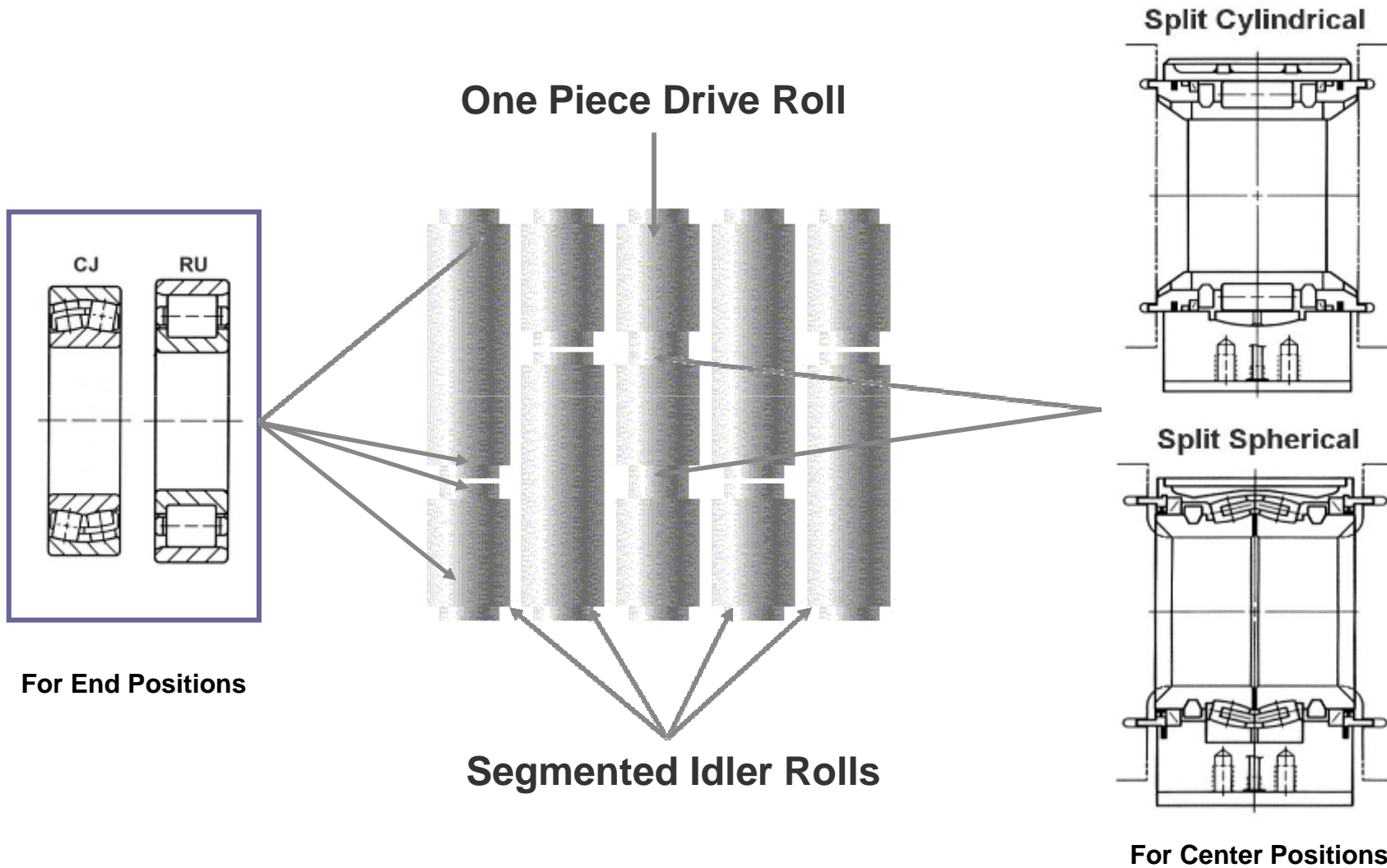

Typical Plate Mill Configuration – Back-up Roll

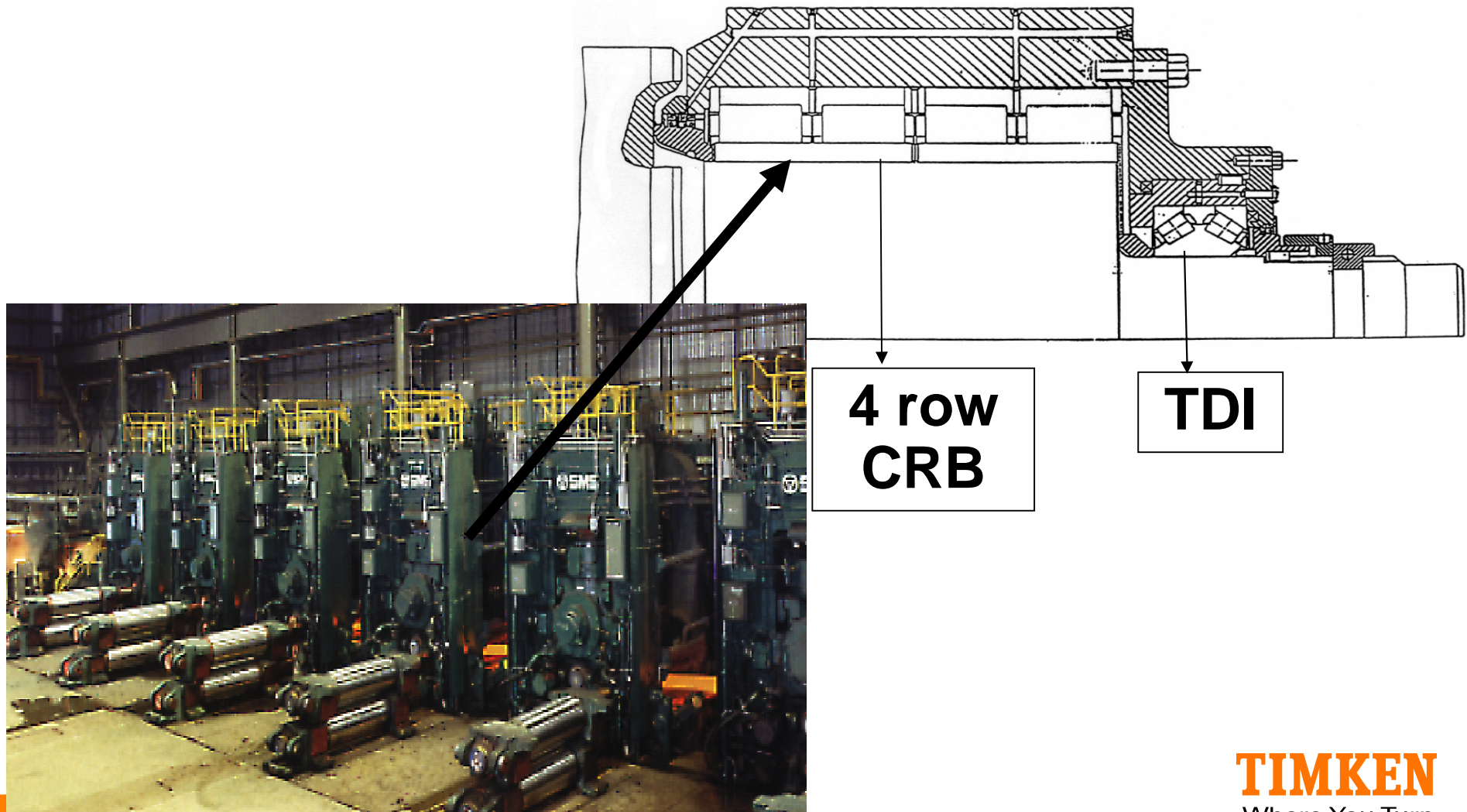

Typical Bar Mill Configuration – Work Roll



Radial bearing
4-row CRB
Open or Sealed
(bore 140-400mm)

Axial bearing
TTDWK

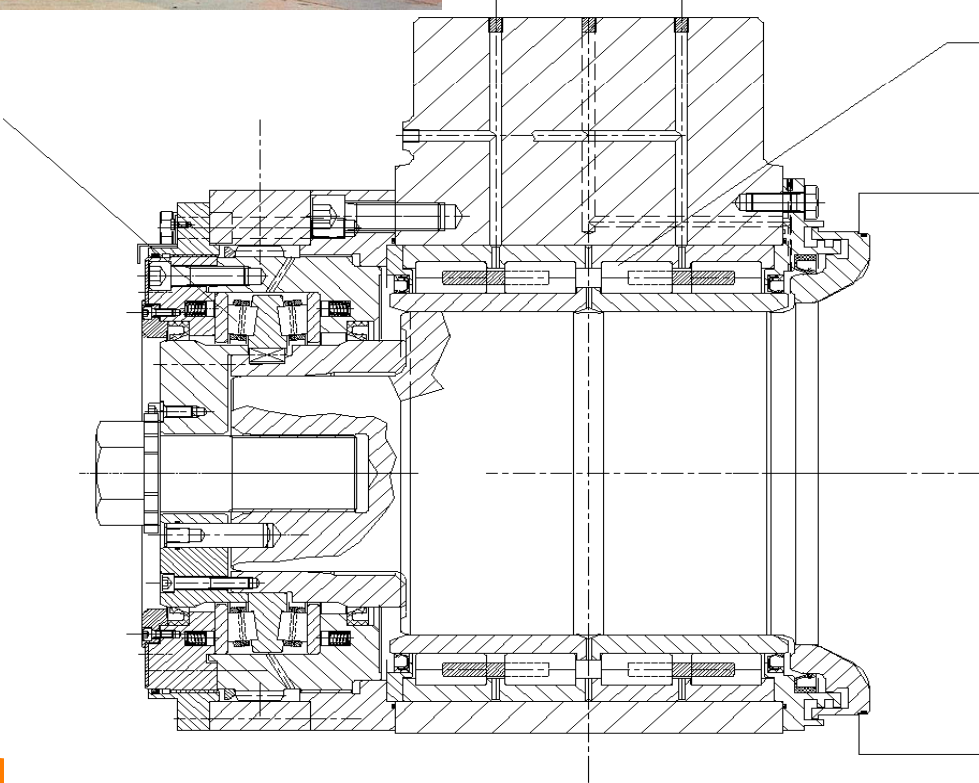

Aridos – Machacadora de Cono

- Upper radial bearing: CRB
- Lower radial bearing: CRB
- Upper thrust bearing: Thrust TRB (TTVF type)
- Lower thrust bearing: Thrust CRB (TP type)
- Pinion shaft: TRB (TS type)

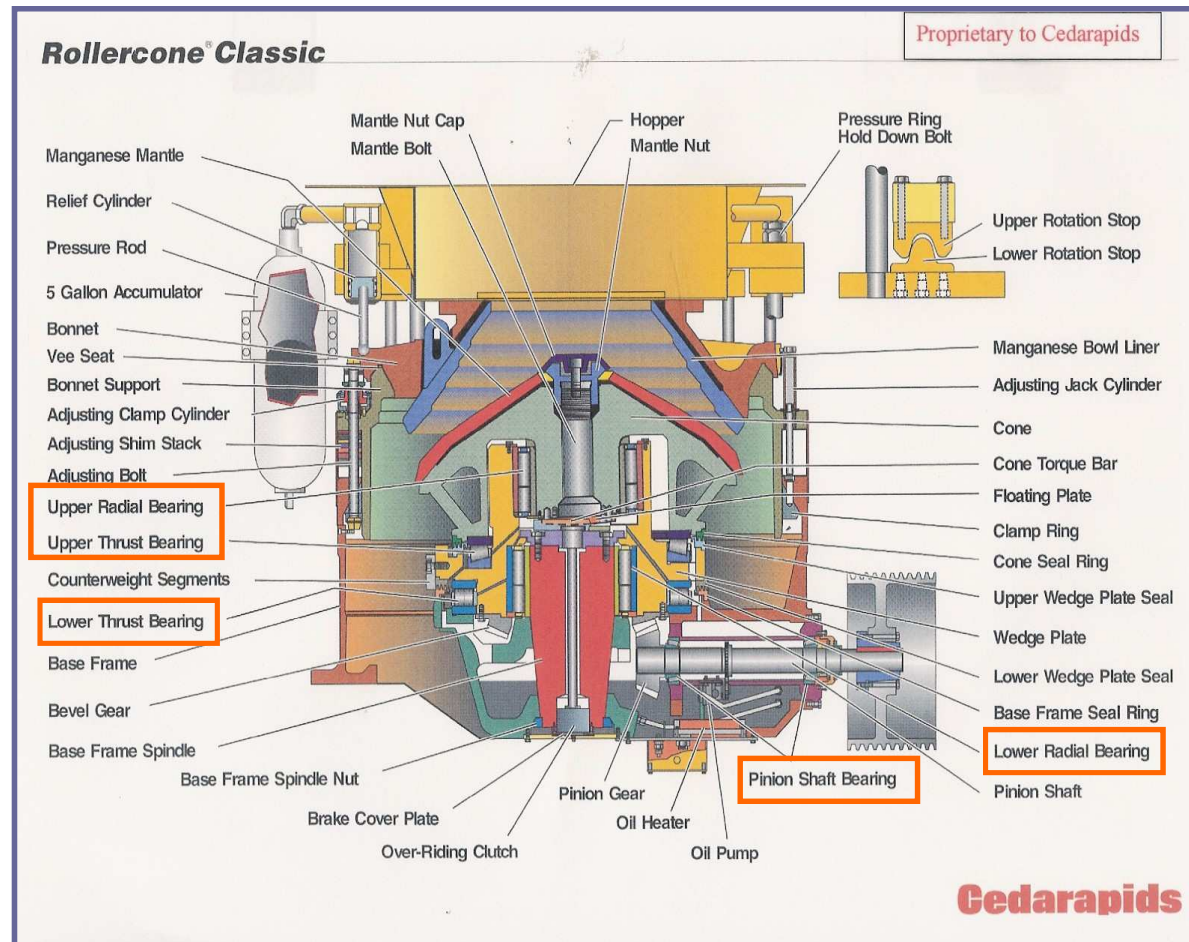

Aridos- Criba Horizontal

- Reciprocating action
- Uses multiple shafts with two bearings per shaft

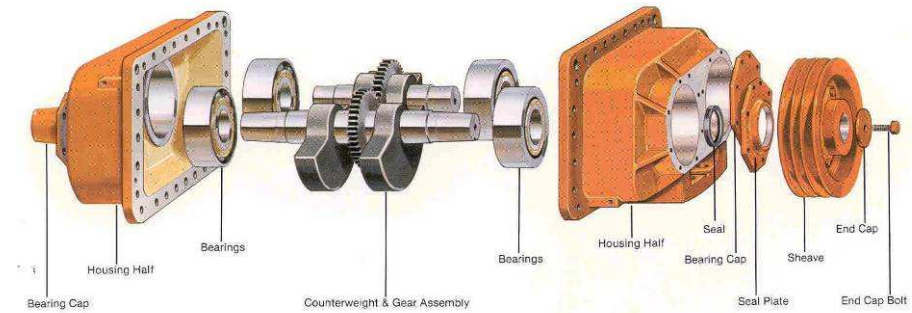

Low Head Screen Bearing Assembly (CRBs)



Construction – Front End Loader

- N style CRB's Outboard planetary

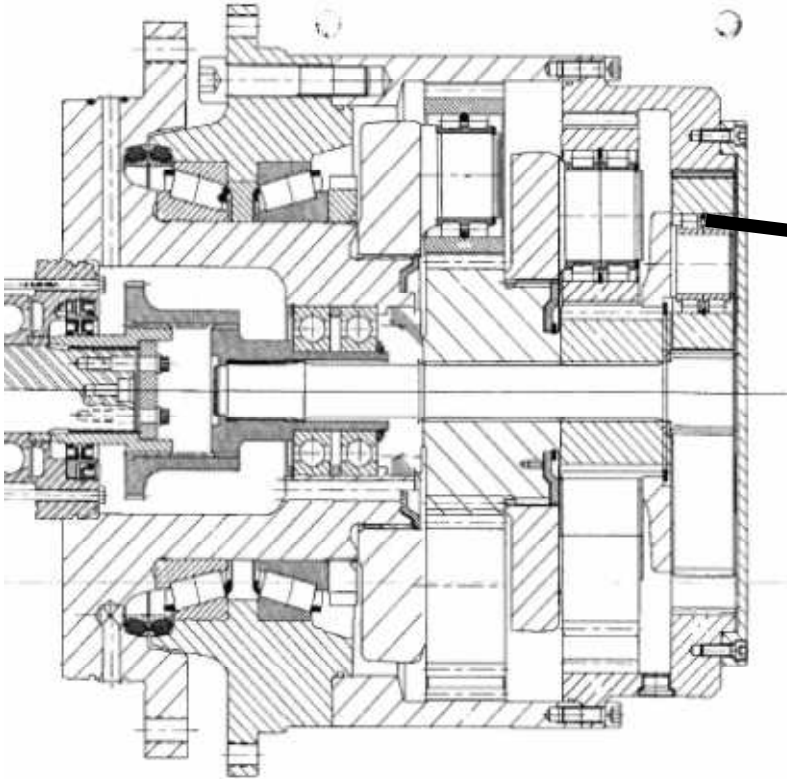

Construction – Vibratory Compactors

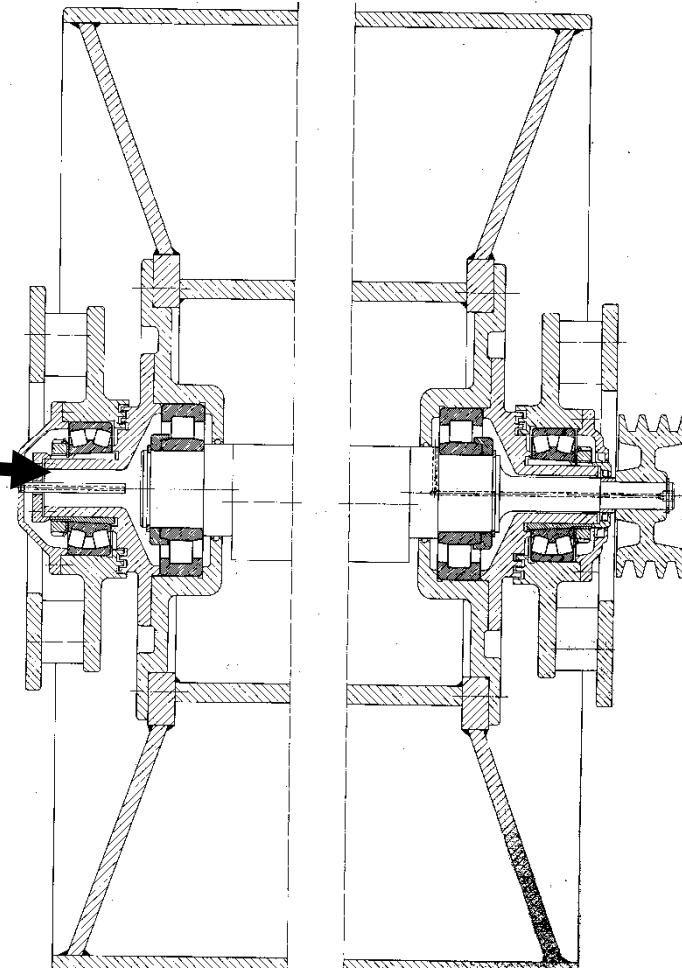

- NU style CRB's with HJ rings for incidental axial contact

Mining Applications



Swing Arms

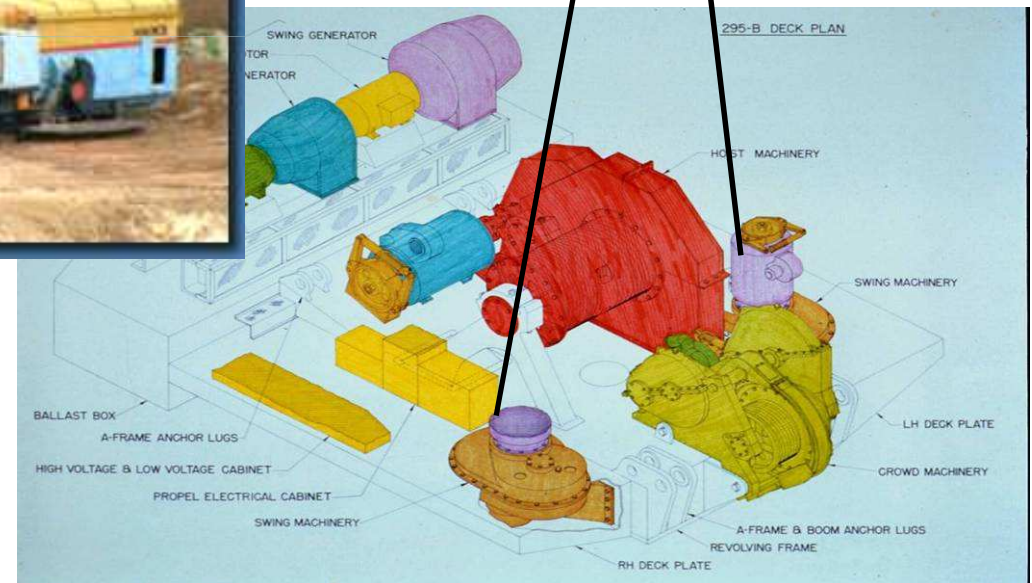

TIMKEN
Where You Turn

Swing Gear Train

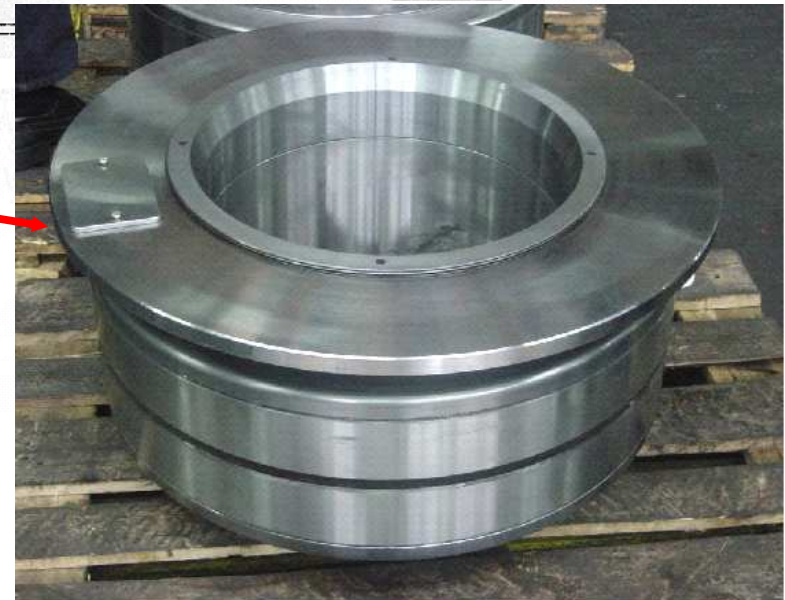
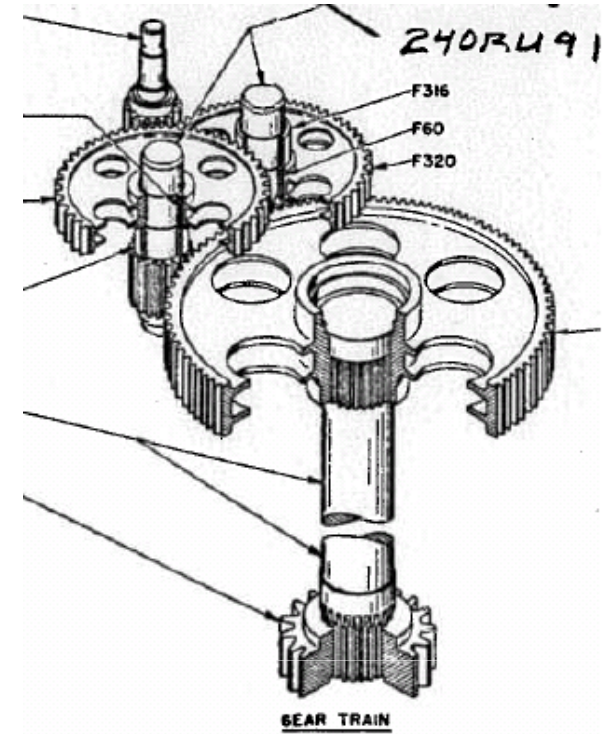
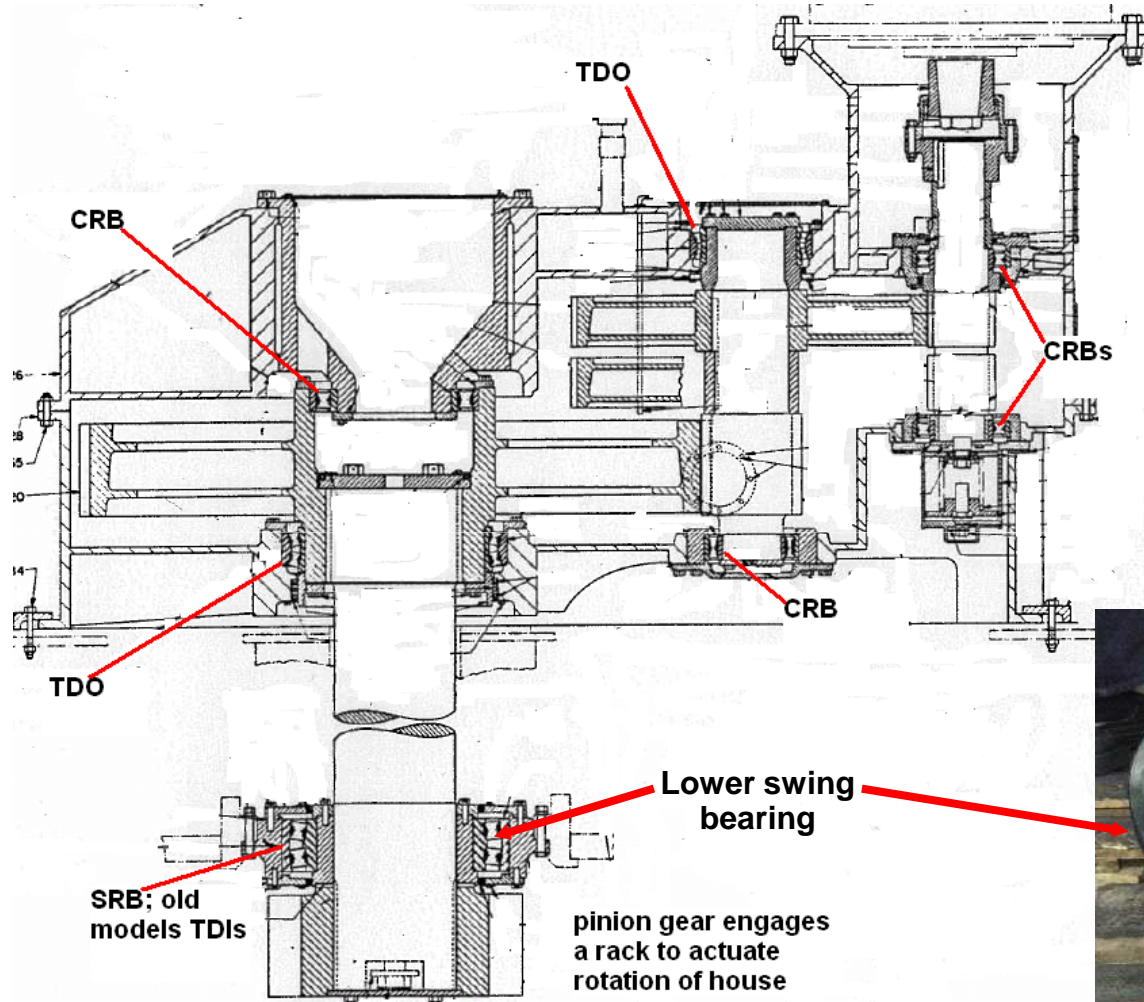

Continuous Miner

- CRB's planetary
- CRB's at drum positions as opposed to TRB's
- TRB's at spiral bevel gear

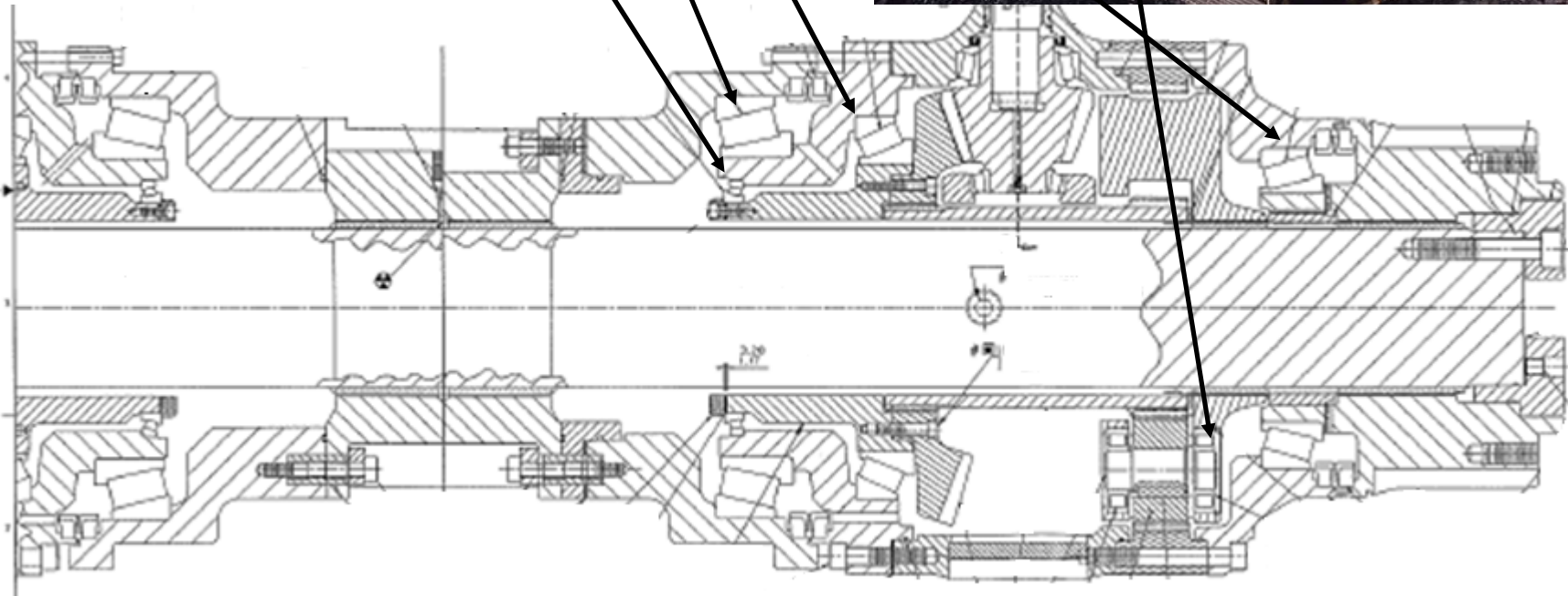

Longwall Shears

- Motor Input
- TRB's Cutter head
- NJ CRB's Idlers
- CRB planets

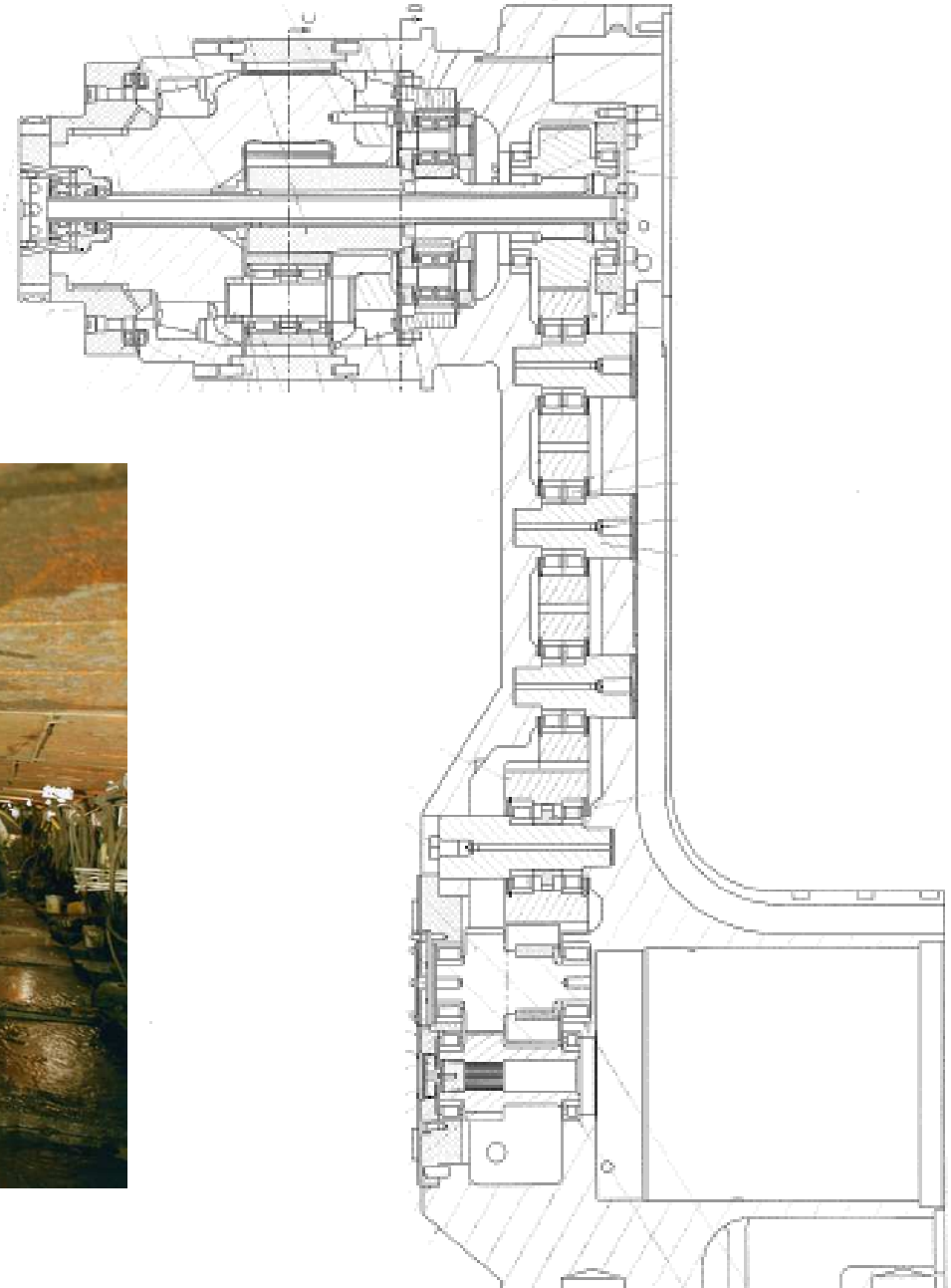

Pulverizer Wheels

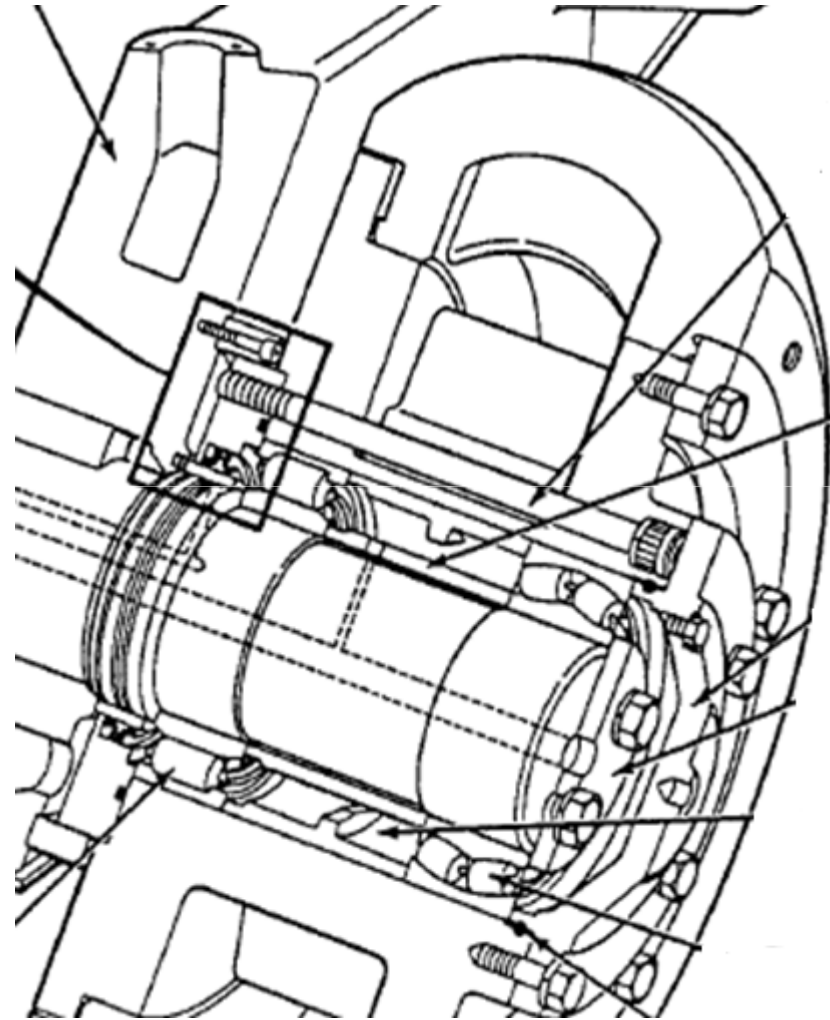

Mud Pump

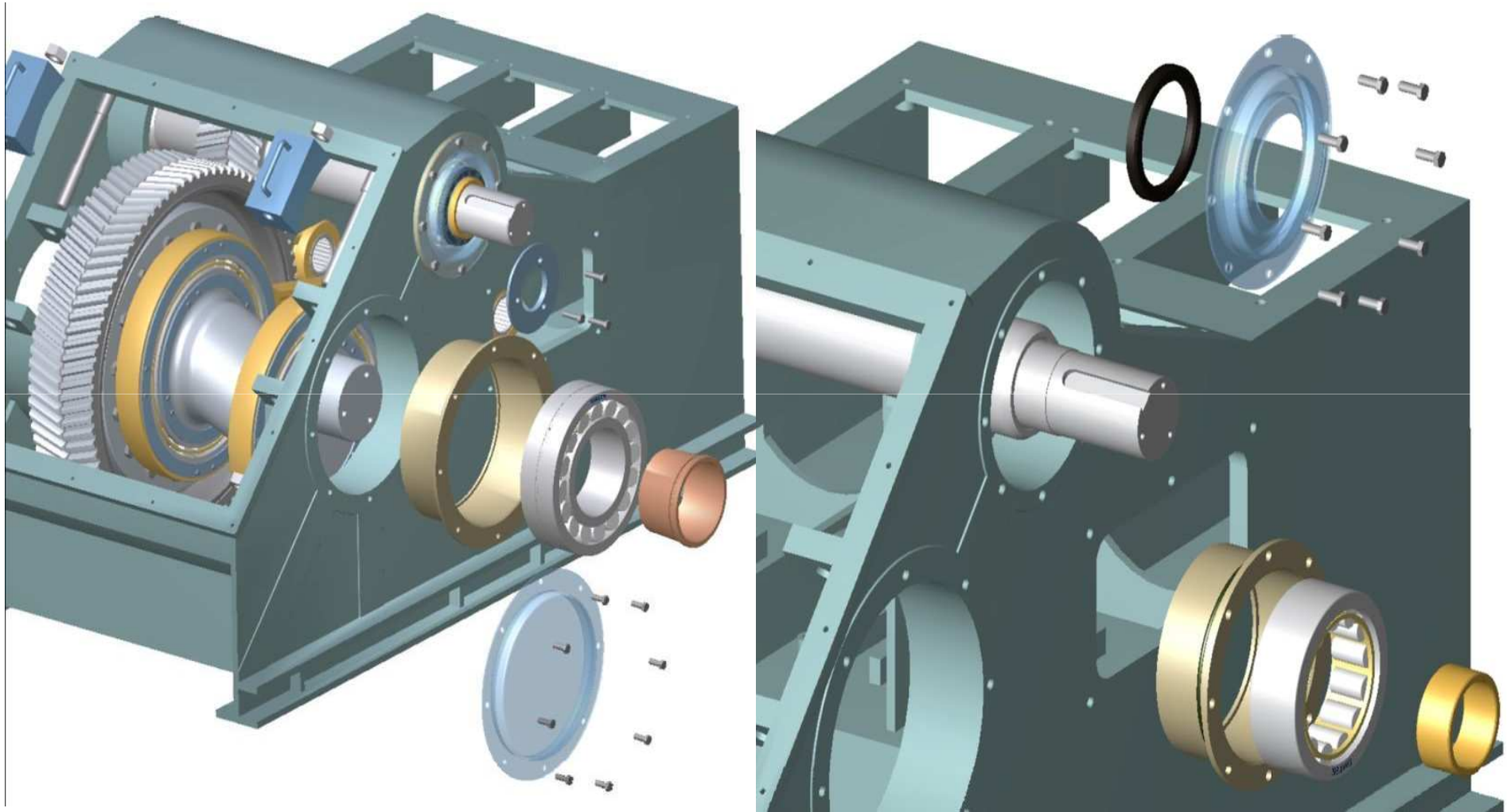

Mud Pump

- Crank - Eccentric
 - Fractured Cylindrical
- Pinion/Crank - Support
 - TRB, CRB, SRB

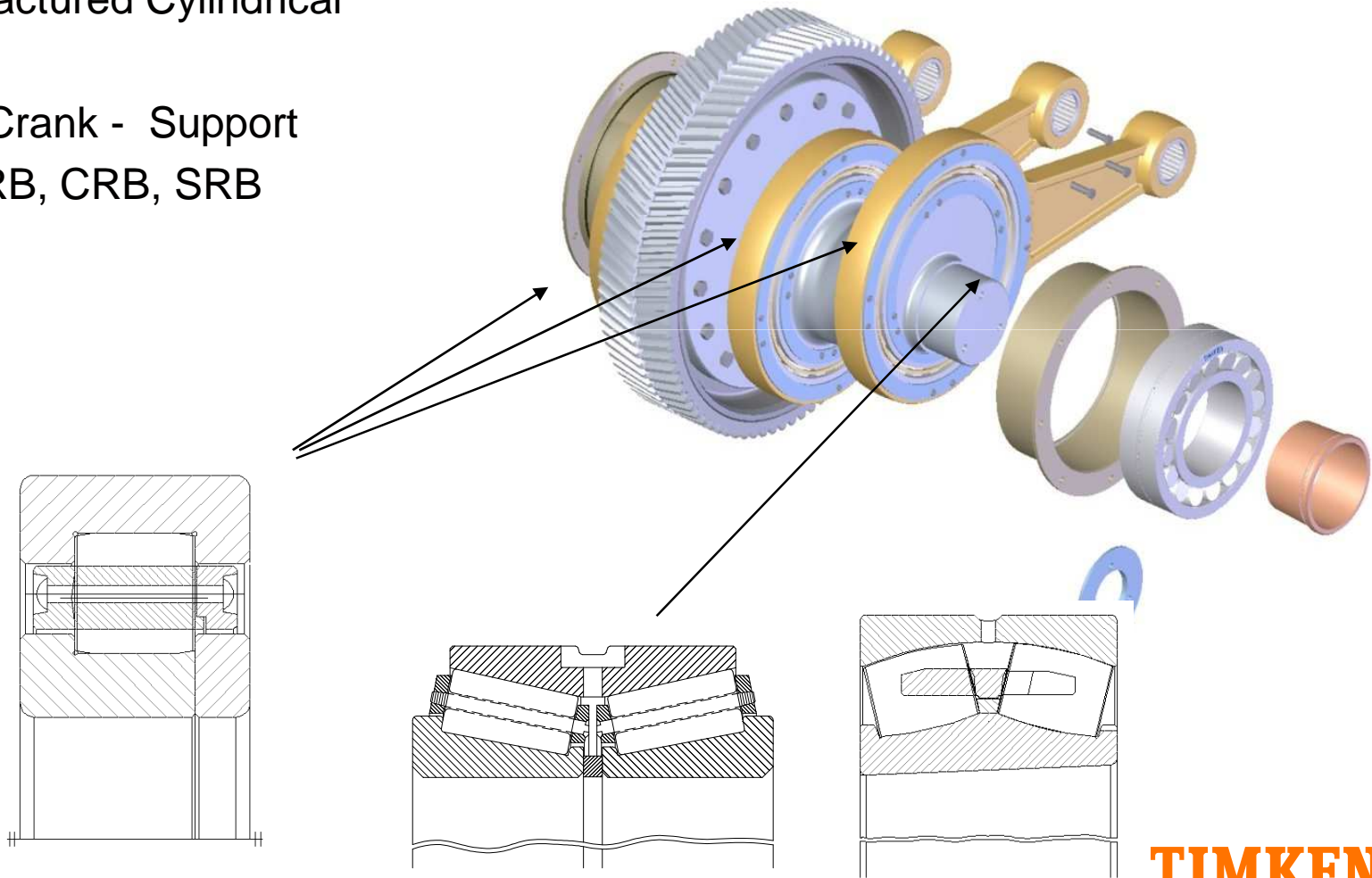

Wind Turbines

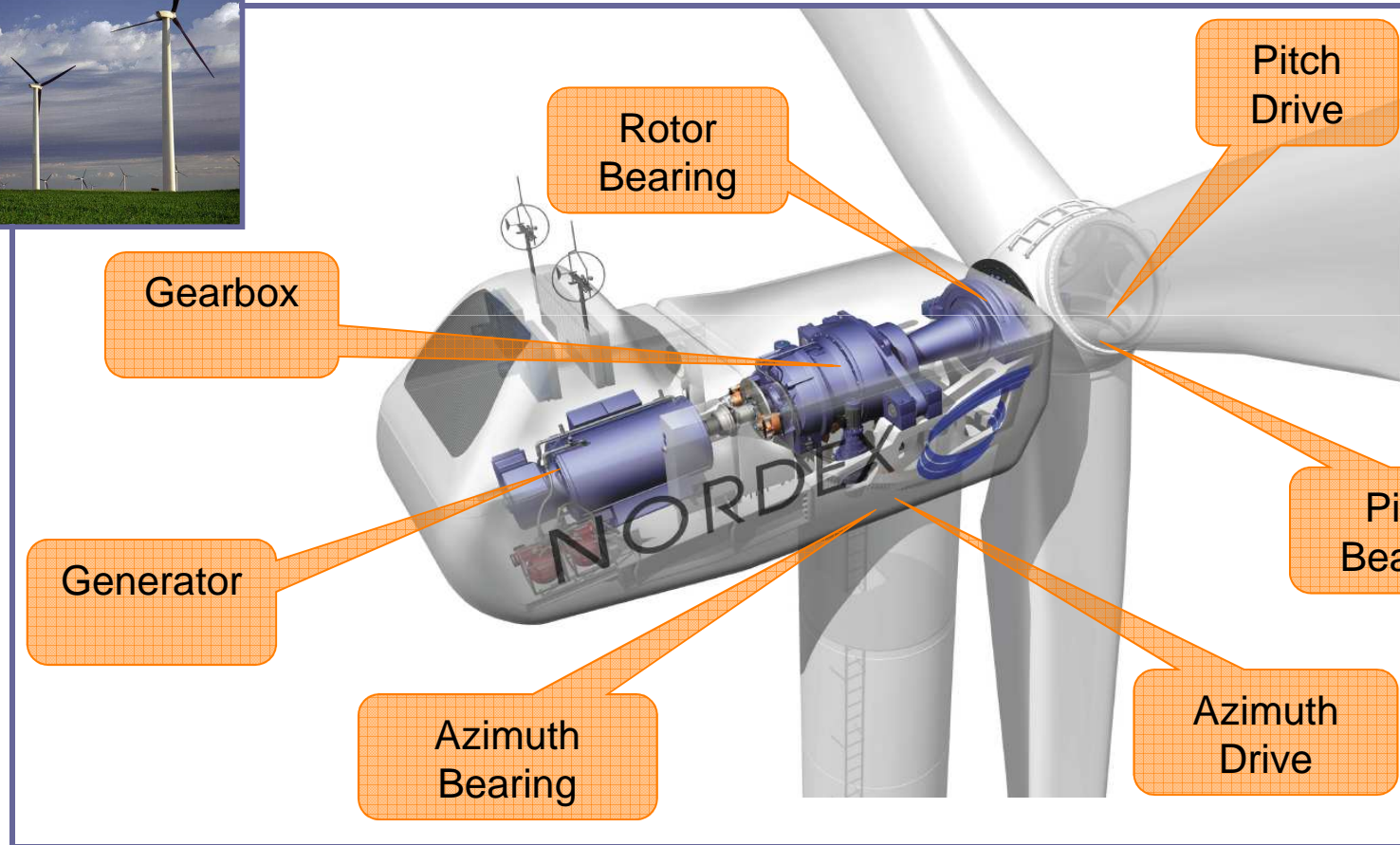

Wind Turbines – Gear Drive

- NJ CRB's Carriers
- NJ CRB's Planets
- NU high speed output

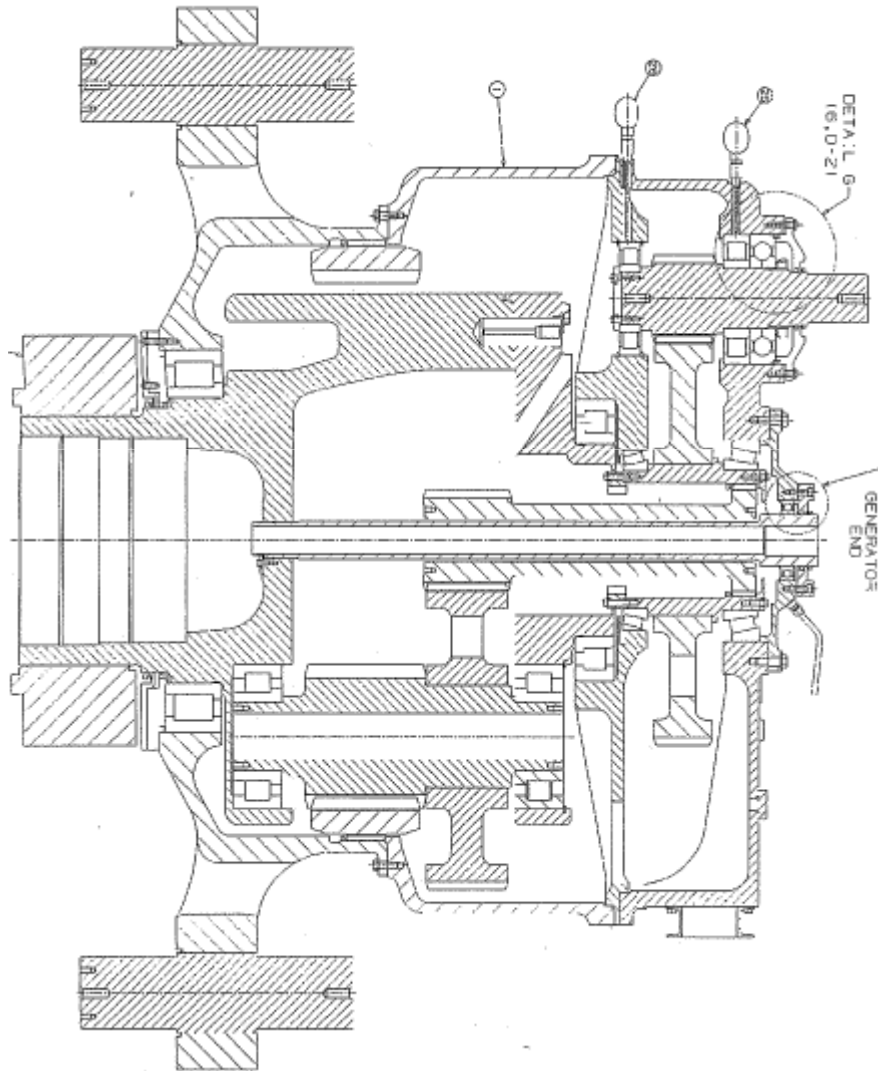

Slurry Pump

- Tandem Ball Bearing Fix Position
- CRB Float Position

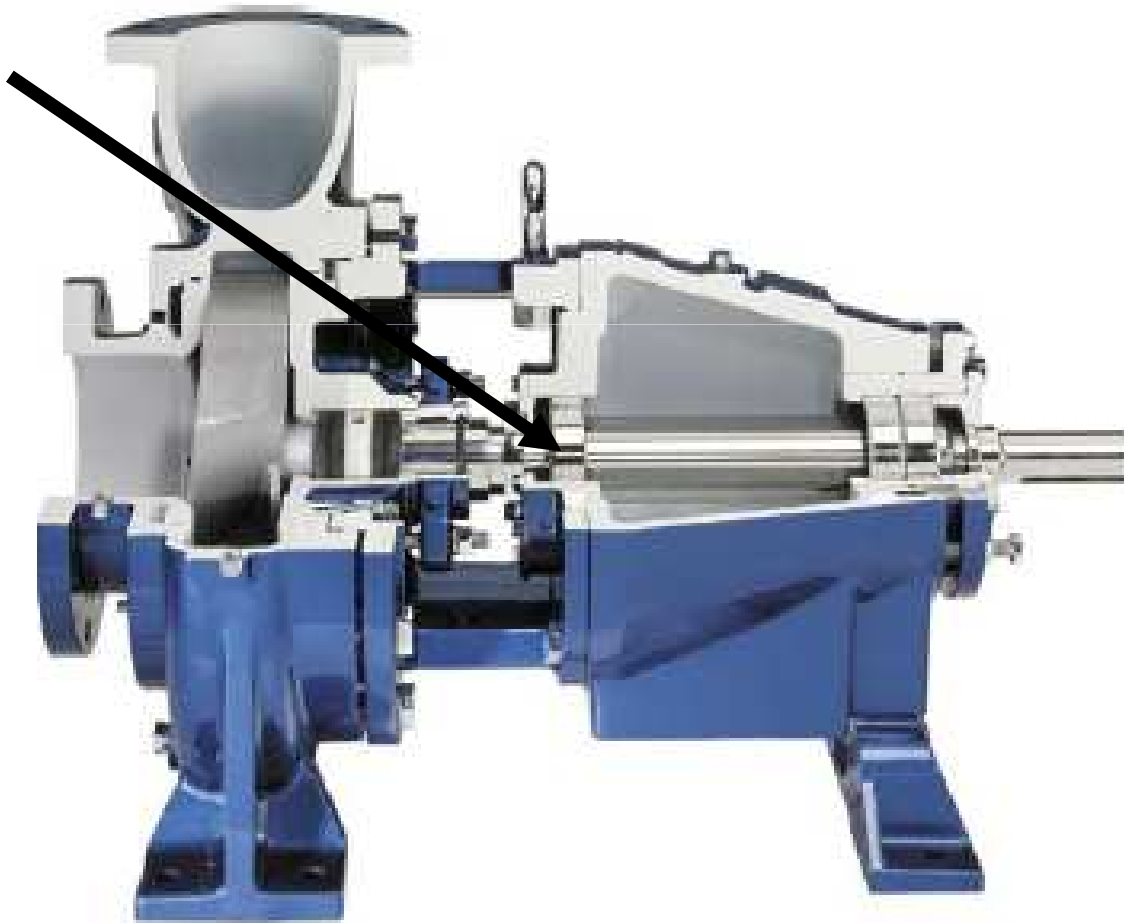

Slurry Pump

- NU Style Float Position

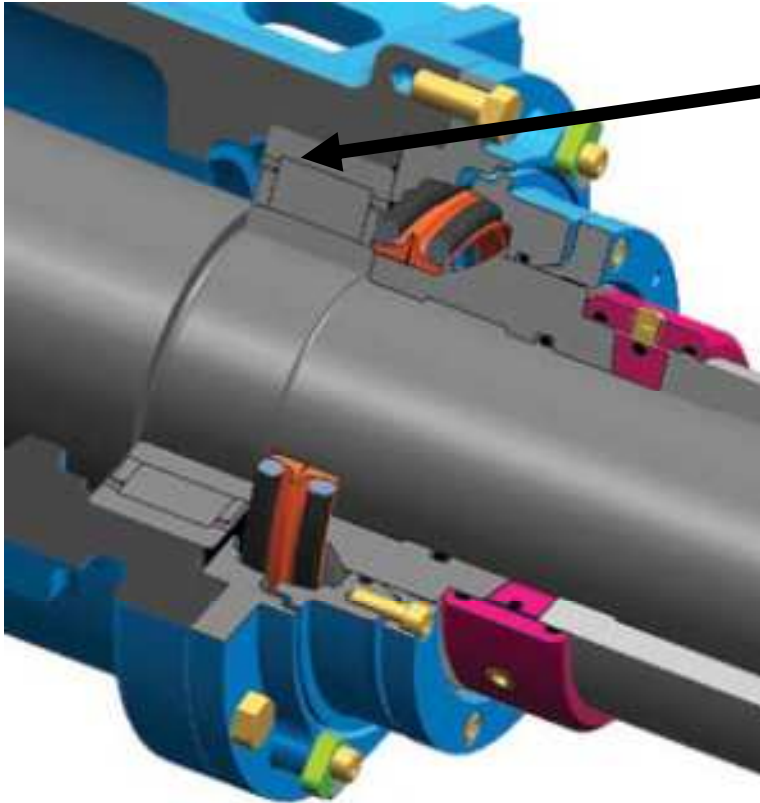

Gear Drives

- Float N Style CRB opposite input TRB Fixed
- N Style CRB on Output with Herringbone Drive

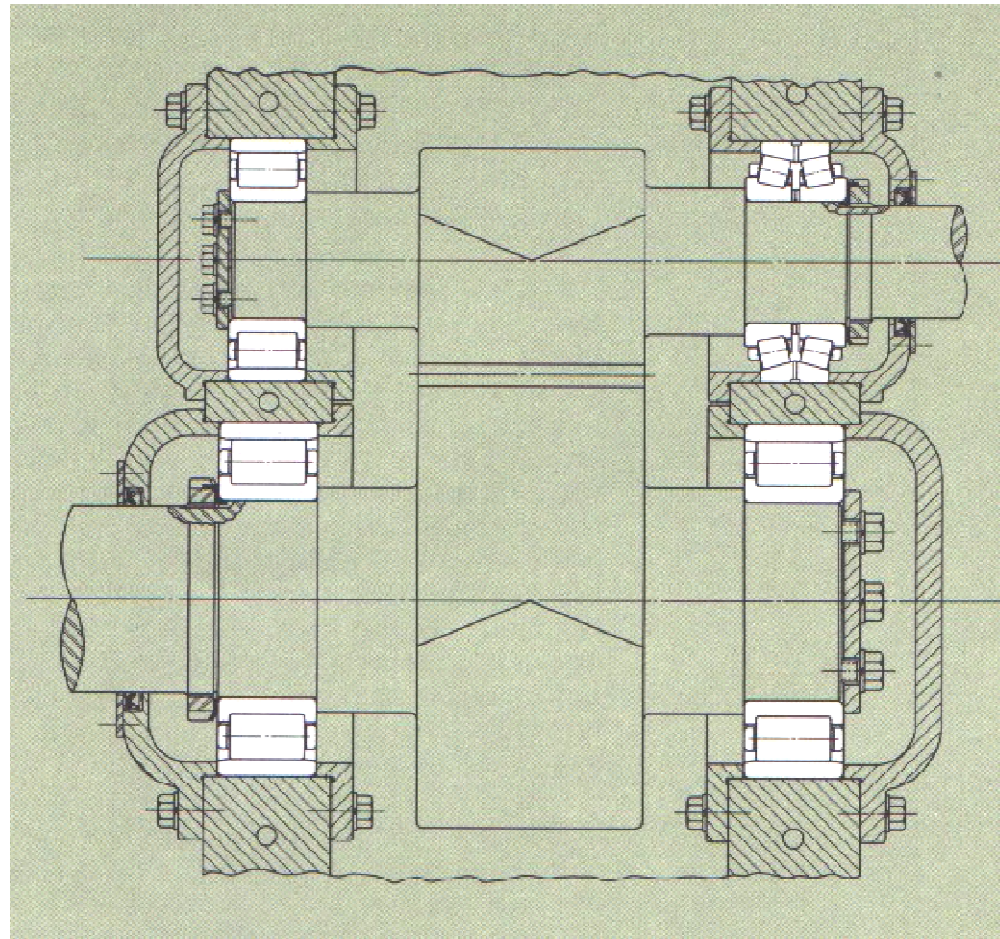

TIMKEN

Where You Turn

TIMKEN
Where You Turn

